

BD SUPER "B" TURBOCHARGER
1994-2002 Dodge 24v ISB
Part #: 1045220

PLEASE READ ALL INSTRUCTIONS BEFORE INSTALLATION

BD ENGINE BRAKE, INC.





Plant Address: A10-33733 King Rd, Abbotsford, BC, Canada V2S 7M9

US Shipping Address: 88-446 Harrison St, Sumas, WA 98295 US Mailing Address: PO Box 231, Sumas, WA 98295

Phone: 604-853-6096 Fax: 604-853-8749 Internet: www.bd-power.com

K I T C O N T E N T S :

Please check to make sure that you have all the parts listed in this kit **before** you start the disassembly your truck.

| DODGE 1994-2002 "SUPER B" SINGLE TURBO KIT (BD# 1045220) | | | |
|---|---|--|---|
| 1405215 | 1405926 | 1045927 | 1100740 |
|  |  |  |  |
| <i>Super "B" Single Turbo</i> | <i>Turbo Clamp</i> | <i>4" Down Pipe</i> | <i>4" Stainless Steel Down Pipe Clamp</i> |
| Qty: 1 | Qty: 1 | Qty: 1 | Qty: 1 |

| 24V Installations |
|--|
| 1405986 |
|  |
| <i>Manifold bolt M10x1.5x45</i> |
| Qty: 2 |

A turbocharger is driven solely on exhaust energy. Therefore, if the vehicles current exhaust manifold is cracked or is leaking, it is recommend that new exhaust gaskets and a heavy-duty exhaust manifold be used.

Installation should occur on a cold vehicle, as turbo and exhaust components become very hot with use.

The BD Super B system is recommended for trucks with 300-400 RWHP with a maximum efficient boost pressure of 45psi. For optimum performance, the turbo should operate between 37–45psi.

BD ENGINE BRAKE, INC.

Plant Address: A10-33733 King Rd, Abbotsford, BC, Canada V2S 7M9

US Shipping Address: 88-446 Harrison St, Sumas, WA 98295 US Mailing Address: PO Box 231, Sumas, WA 98295

Phone: 604-853-6096 Fax: 604-853-8749 Internet: www.bd-power.com

UPGRADE OPTIONS

| <u>Description</u> | <u>Part #</u> |
|------------------------------------|----------------------|
| BD 'X' Torque Converter | 1070215X |
| BD Transmission | CALL |
| BD High Flow Injectors | CALL |
| BD Lift pump kit 24V | 1050226 |
| BD High Flow Banjo Bolts 24V | 10502XX |
| Heavy Duty Exhaust Manifold 24V | 1045985 |
| Heavy Duty Exhaust Manifold 12V | 1045980 |
| BD X-Monitor | CALL |
| BD High Pressure Intercooler Boots | 1405220 |
| BD Cool Down Timer | 1081150 |

BD ENGINE BRAKE, INC.

Plant Address: A10-33733 King Rd, Abbotsford, BC, Canada V2S 7M9

US Shipping Address: 88-446 Harrison St, Sumas, WA 98295 US Mailing Address: PO Box 231, Sumas, WA 98295

Phone: 604-853-6096 Fax: 604-853-8749 Internet: www.bd-power.com

BATTERY DISCONNECT

Disconnect the negative terminals on both of the vehicle's batteries, and then disconnect the positive terminals.

INSTALLATION

Record radio settings and disconnect both battery terminals on both batteries.

Lay a protective cover over the passenger side fender to eliminate any scratches.

Remove the air box assembly and intake tube from inlet of turbocharger.

Remove the two 13mm bolts connecting the exhaust down pipe to the turbo flange.

Remove the v-band clamp on the turbo compressor-housing outlet that connects to the intercooler. Be sure not to lose the orange o-ring from the intercooler inlet tube elbow. Also make sure that you cover the intercooler tube so debris does not fall inside.

Remove the turbo oil feed line and un-bolt the turbo oil drain tube and cover the inlet to protect it from contamination.

Remove the four nuts holding the turbo to the exhaust manifold. Remove the stock turbo and set it aside.

Inspect the exhaust manifold for shrinkage, cracks and leaks. If none are found, remove the original turbo gasket and clean the turbo-mating surface. If any cracks are found, you will need to replace the manifold with a stock replacement or a heavy-duty aftermarket version.

Remove the turbo down pipe. Note that it is assumed that the user has a full 4" exhaust system at the time of install, not a CAT back system or stock exhaust.

Remove the original gasket from the oil drain tube sealing flange and replace with the new gasket provided.

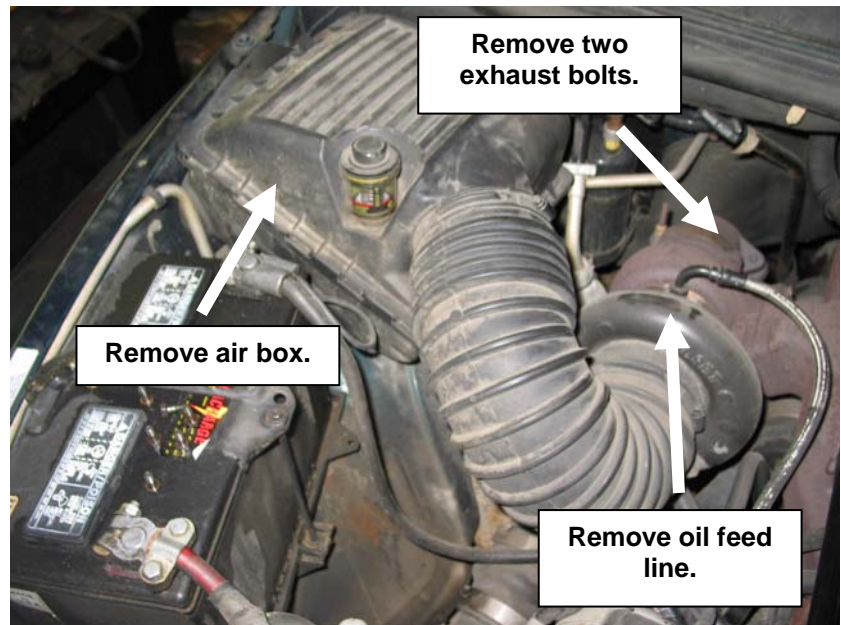

BD ENGINE BRAKE, INC.

Plant Address: A10-33733 King Rd, Abbotsford, BC, Canada V2S 7M9

US Shipping Address: 88-446 Harrison St, Sumas, WA 98295 US Mailing Address: PO Box 231, Sumas, WA 98295

Phone: 604-853-6096 Fax: 604-853-8749 Internet: www.bd-power.com

Install the "Super B" turbo with the supplied gasket and the four factory nuts (gasket direction is unimportant) to the exhaust manifold. Torque to 24 ft lbs. For 24V installations two M10x1.5x45mm bolts have been provided.

TURBO CLOCKING/ALIGNING (If Necessary)

Loosen the four bolts clamping the exhaust housing to the turbo body and rotate body until oil feed drains are straight up and down. Re-tighten the four bolts. Loosen the eight bolts clamping the turbo compressor housing to the body and rotate housing to align with intercooler tube. You need to align the compressor outlet to the stock cast aluminum elbow with the orange o-ring in it. Now tighten the eight bolts holding the compressor housing to the body to secure its position.

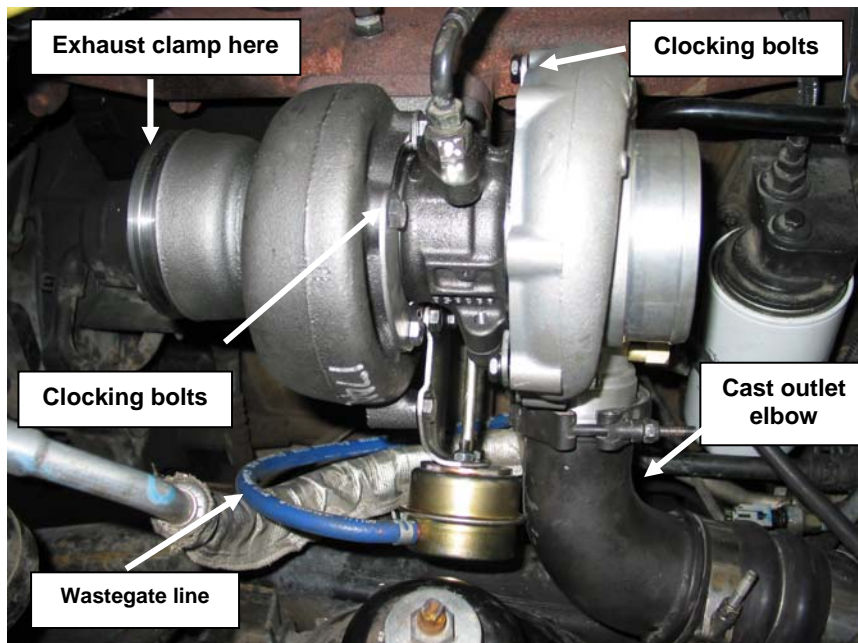

Ensure the orange o-ring is in place and use the factory v-band clamp to connect to compressor housing to the intercooler elbow and tube. Adjustment of the first intercooler boot may be required for a proper fit.

Connect the oil drain tube to the bottom of the turbo using the supplied gasket and the original hardware. You will need to slide the oil drain adapter as far as possible away from the wastegate arm to prevent any contact. In some rare cases the wastegate arm may need to be bent.

Be sure to squirt fresh oil down the oil feed port while rotating the compressor wheel. This will ensure a smooth start-up and reduce the chance of damaging the bearings.

Remove the oil feed line adapter from stock turbo and install in the "Super B" turbo. Be sure to inspect the adapters o-ring for any damage to reduce the chance of an oil leak. Install the oil feed line.

Ensure the brass barb fitting in the compressor housing is tight and install blue rubber wastegate hose and clamp the end to the wastegate.

Install the new down pipe to the rear of the turbo. It is highly recommended to loosely clamp all exhaust pieces together to ensure proper fit before tightening anything.

BD ENGINE BRAKE, INC.

Plant Address: A10-33733 King Rd, Abbotsford, BC, Canada V2S 7M9

US Shipping Address: 88-446 Harrison St, Sumas, WA 98295 US Mailing Address: PO Box 231, Sumas, WA 98295

Phone: 604-853-6096 Fax: 604-853-8749 Internet: www.bd-power.com

Position all exhaust clamps ¼" from joints and if possible tack weld all pipes to prevent twisting.

You can now install the factory air box and intake tube. Double check all clamps to ensure they are tight.

Reconnect negative battery terminals and start the vehicle. Check for any exhaust or oil leaks.

Take it easy on the turbo for the first 100 miles to allow a proper break-in period. Be very cautious of any unusually sounds or leaks during this time.

Note: The exhaust housing of the turbo may smoke when new as manufacturing residue on housing must burn off.

1994-95 Trucks

When installing the turbo on 1994-95 trucks you will need to remove the steel wastegate line that is connected to the factory turbo and the AFC housing of the P7100 fuel injection pump.

With this line disconnected you will need to plug off the connection point at the AFC housing with a 1/8" NPT plug.

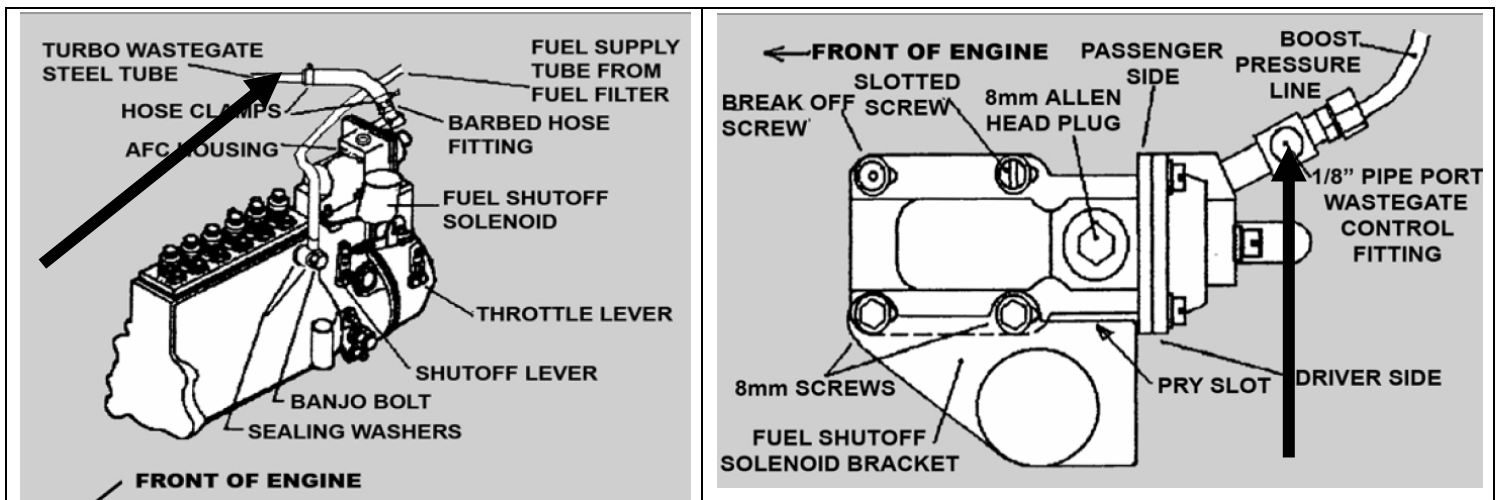

BD ENGINE BRAKE, INC.

Plant Address: A10-33733 King Rd, Abbotsford, BC, Canada V2S 7M9

US Shipping Address: 88-446 Harrison St, Sumas, WA 98295 US Mailing Address: PO Box 231, Sumas, WA 98295

Phone: 604-853-6096 Fax: 604-853-8749 Internet: www.bd-power.com

**BD ENGINE BRAKE, INC.
LIMITED WARRANTY STATEMENT**

THE INSTALLATION OF THIS PRODUCT INDICATES THAT THE BUYER HAS READ AND UNDERSTANDS THIS AGREEMENT AND ACCEPTS ITS TERMS AND CONDITIONS.

DISCLAIMER OF LIABILITY

BD Engine Brake Inc., its successors, distributors, jobbers, and dealers (hereafter "**BD**") shall in no way be responsible for the product's proper use and service. THE BUYER HEREBY WAIVES ALL LIABILITY CLAIMS.

BD disclaims any warranty and expressly disclaims any liability for personal injury or damages. **BD** also disclaims any liability for incidental or consequential damages including, but not limited to, repair labor, rental vehicles, hotel costs, or any other inconvenience costs by reason of use or sale of any such equipment. The **BUYER** acknowledges and agrees that the disclaimer of any liability for personal injury is a material term for this agreement and the **BUYER** agrees to indemnify **BD** and to hold **BD** harmless from any claim related to the item of any equipment purchased.

This warranty shall not apply to any unit that has been improperly stored or installed, or to misapplication, improper operation conditions, accidents, neglect, or which has been improperly repaired or altered or otherwise mistreated by the **BUYER** or his agent. **BD** also assumes no liability regarding the improper installation or misapplication of its products. It is the installer's responsibility to check for proper installation and if in doubt, contact the manufacturer.

LIMITATION OF WARRANTY

BD Engine Brake Inc. (hereafter "**BD**") warrants to the **BUYER** that any parts purchased shall be free from defects in material workmanship. A defect is defined as a condition within the product that would render the product inoperable. **BD** gives Limited Warranty as to description, quality, merchantability, fitness for any product's purpose, productiveness, or any other matter of **BD's** product sold herewith. **BD** shall be in no way responsible for the product's open use and service and the **BUYER** hereby waives all rights other than those expressly written herein. This Warranty shall not be extended or varied except by a written instrument signed by **BD** and the **BUYER**.

The Warranty is Limited to one (1) year from the date of sale. Until BD has approved the claim, the consumer may be responsible for these costs.

A Return Material Authorization (RMA) number, obtained in advance from **BD**, must accompany all products returned for warranty consideration. All products must be returned, shipping prepaid, to **BD** and must be accompanied by a dated proof of purchase receipt. All Warranty claims are subject to approval by **BD** and repaired or replaced product will be returned to the customer freight collect. Accepted warranty units, which have been replaced, become the sole property of **BD**.

This warranty is in lieu of all other warranties or guaranties, either expressed or implied, and shall not extend to any consumer or to any person other than the original purchaser residing within the boundaries of the continental U.S. or Canada.

IN THE EVENT THAT THE BUYER DOES NOT AGREE WITH THIS AGREEMENT, THE BUYER MAY PROMPTLY RETURN THIS PRODUCT, IN A NEW AND UNUSED CONDITION, WITH A DATED PROOF OF PURCHASE, TO THE PLACE OF PURCHASE WITHIN THIRTY (30) DAYS FROM DATE OF PURCHASE FOR A FULL REFUND.

Damaged or blown head gaskets will not be covered under warranty. It is the responsibility of the user to regulate cylinder pressures to protect the head gasket and turbo.

BD ENGINE BRAKE, INC.

Plant Address: A10-33733 King Rd, Abbotsford, BC, Canada V2S 7M9

US Shipping Address: 88-446 Harrison St, Sumas, WA 98295 US Mailing Address: PO Box 231, Sumas, WA 98295

Phone: 604-853-6096 Fax: 604-853-8749 Internet: www.bd-power.com