

## REMOVAL

### 1. REMOVE RADIATOR GRILLE

- (a) Using a clip remover, remove the 2 clips.
- (b) Remove the 2 screws.
- (c) Disengage the 5 clips and remove the radiator grille.

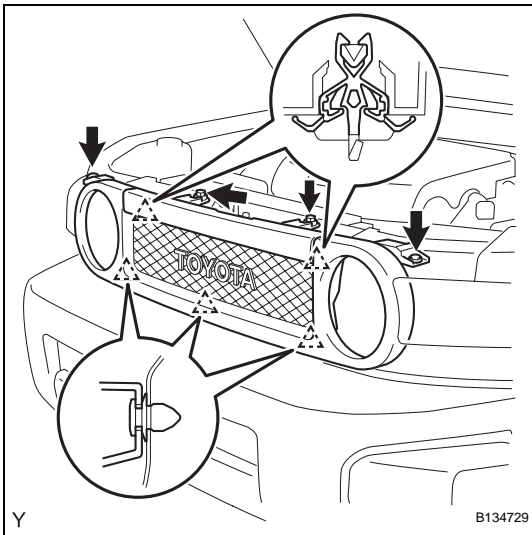

### 2. REMOVE FRONT BUMPER COVER

- (a) Apply protective tape as shown in the illustration.

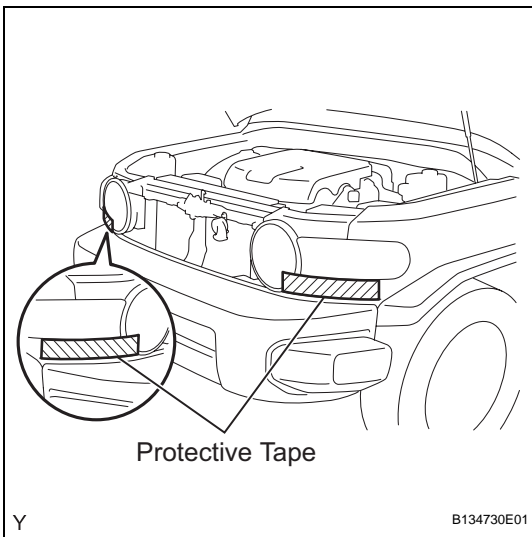

- (b) Using a clip remover, remove the 5 clips.

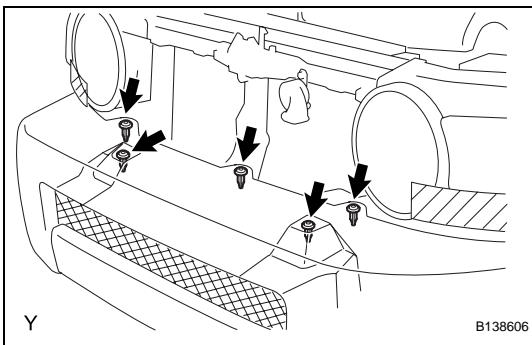

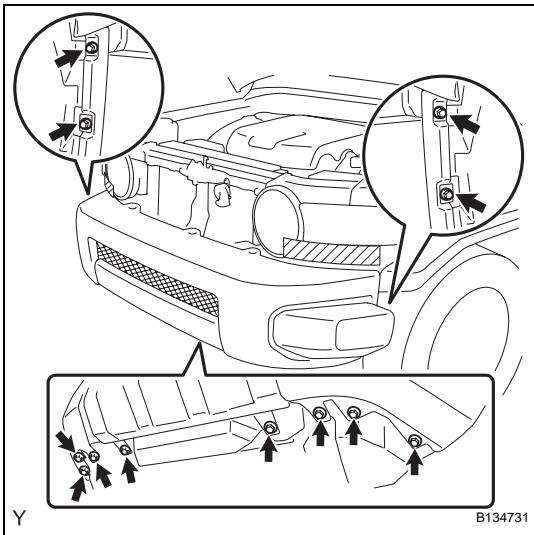

(c) Remove the 8 screws and the 4 bolts.

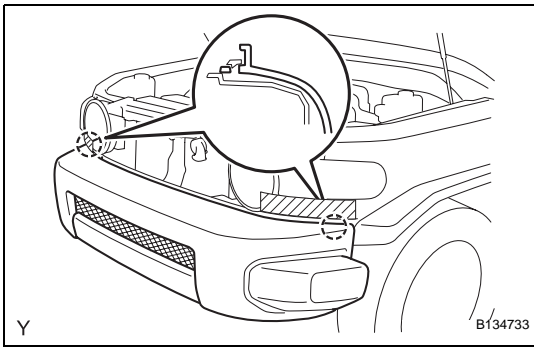

(d) Disengage the 2 claws and remove the front bumper cover.

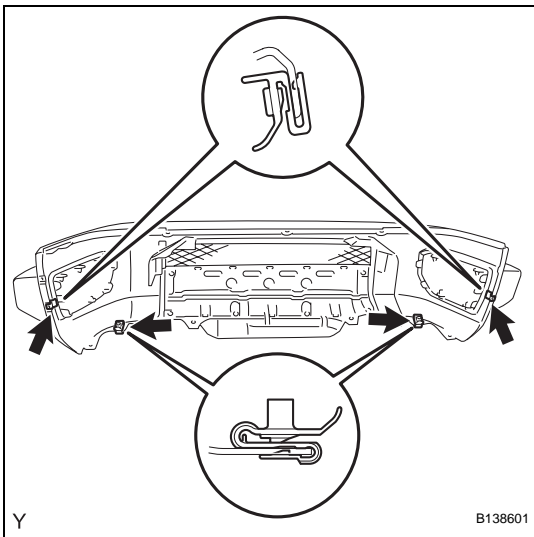

(e) Remove the 4 clips.

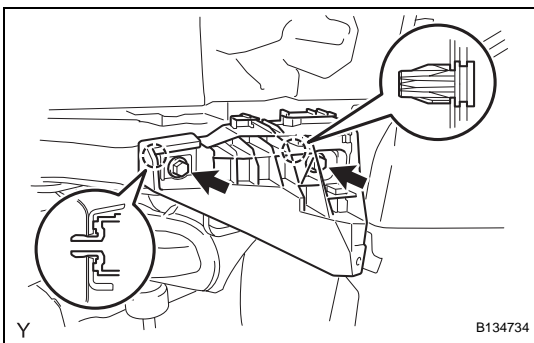

**3. REMOVE FRONT BUMPER SIDE SUPPORT LH**

- (a) Remove the 2 screws.
- (b) Disengage the 2 claws and remove the front bumper side support.

**4. REMOVE FRONT BUMPER SIDE SUPPORT RH**

**HINT:**  
Use the same procedure as for the LH side.

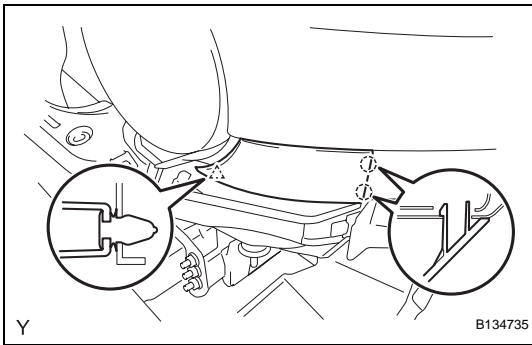

**5. REMOVE FRONT BUMPER FILLER LH**

- (a) Disengage the clip and the 2 claws and remove the front bumper filler.

**6. REMOVE FRONT BUMPER FILLER RH**

HINT:

Use the same procedure as for the LH side.

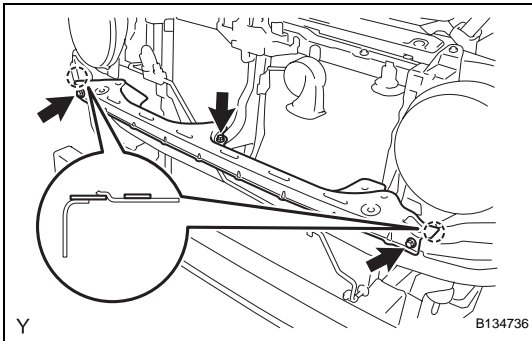

**7. REMOVE FRONT BUMPER UPPER RETAINER**

- (a) Remove the 3 bolts.

- (b) Disengage the 2 hooks and remove the front bumper upper retainer.

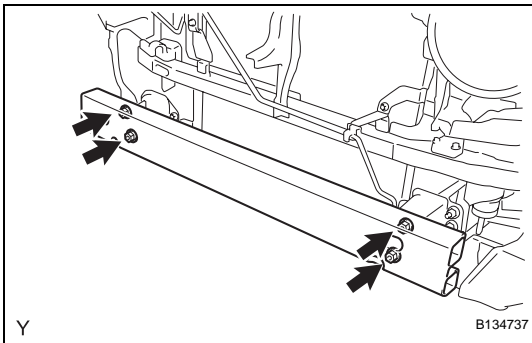

**8. REMOVE FRONT BUMPER REINFORCEMENT**

- (a) Remove the 4 nuts and the front bumper reinforcement.

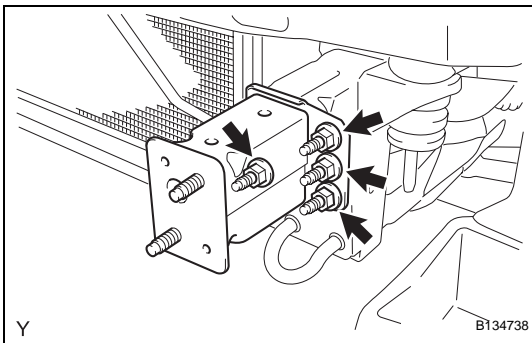

**9. REMOVE FRONT BUMPER EXTENSION LH**

- (a) Remove the 4 nuts and the front bumper extension.

**10. REMOVE FRONT BUMPER EXTENSION RH**

HINT:

Use the same procedure as for the LH side.

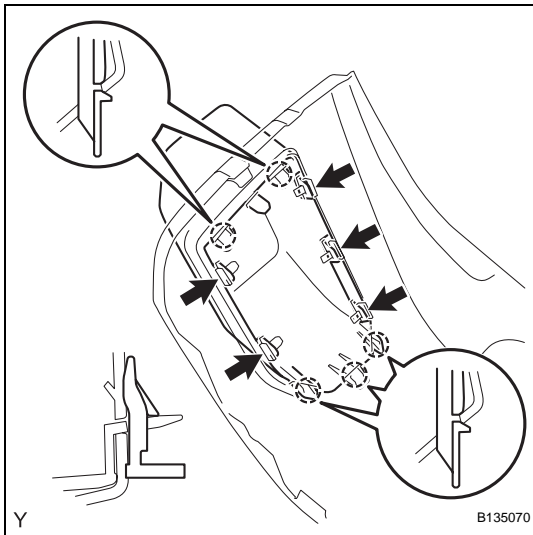
**DISASSEMBLY****1. REMOVE FRONT BUMPER PAD LH**

- (a) Remove the 5 retainers and the front bumper pad.
- (b) Disengage the 5 claws and remove the front bumper pad.

**2. REMOVE FRONT BUMPER PAD RH**

HINT:

Use the same procedure as for the LH side.

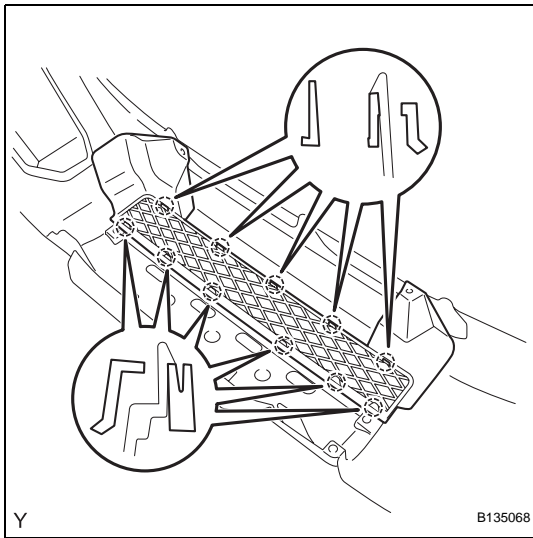
**3. REMOVE RADIATOR LOWER GRILLE**

- (a) Disengage the 11 claws and remove the radiator lower grille.

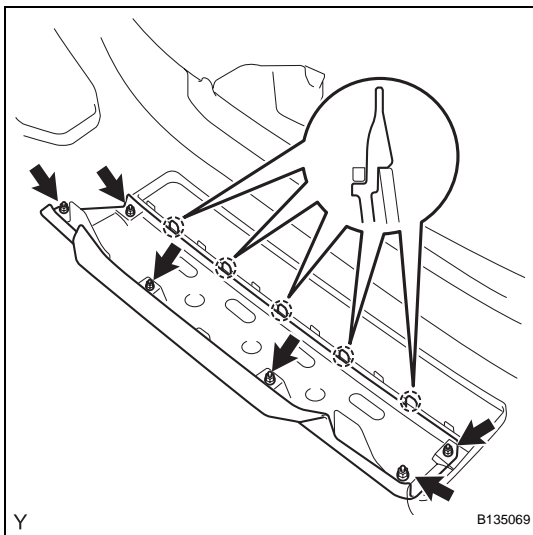
**4. REMOVE FRONT VALANCE LOWER PANEL**

- (a) Remove the 6 nuts.
- (b) Disengage the 5 claws and remove the front valance lower panel.

## REASSEMBLY

### 1. INSTALL FRONT VALANCE LOWER PANEL

- (a) Engage the 5 claws and install the front bumper lower panel.
- (b) Tighten the 6 nuts.

**Torque: 8.0 N\*m (80 kgf\*cm, 71 in.\*lbf)**

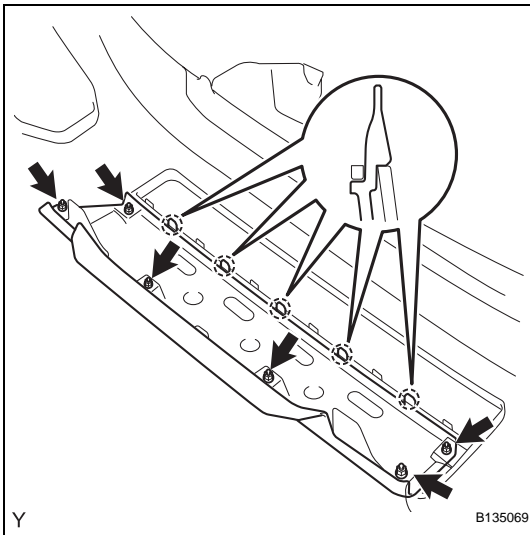

### 2. INSTALL RADIATOR LOWER GRILLE

- (a) Engage the 11 claws and install the radiator lower grille.

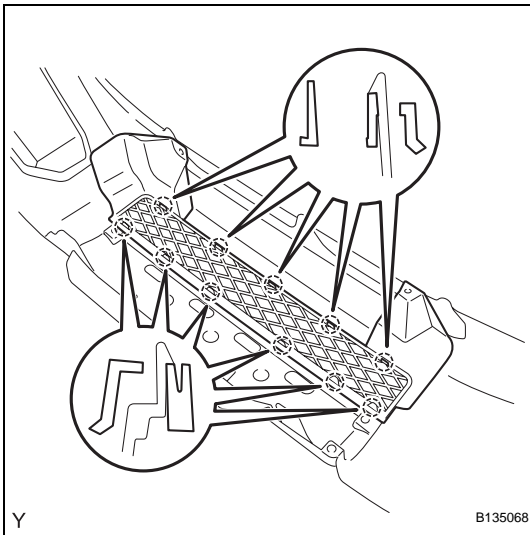

### 3. INSTALL FRONT BUMPER PAD LH

- (a) Engage the 5 claws and install the front bumper pad.
- (b) Install the 5 retainers.

### 4. INSTALL FRONT BUMPER PAD RH

**HINT:**

Use the same procedure as for the LH side.

