

Owner's Manual with Installation Instructions

Banks High-Ram® Intake

**2003-2007 Dodge 5.9L Cummins
(24-valve) ISB Pickup Trucks**

THIS MANUAL IS FOR USE WITH SYSTEM 42726

Gale Banks Engineering
546 Duggan Avenue • Azusa, CA 91702
(626) 969-9600 • Fax (626) 334-1743

Product Information & Sales: (888) 635-4565

bankspower.com

General Installation Practices

Dear Customer,

If you have any questions concerning the installation of your Banks High Ram Intake, please call our Technical Service Hotline at (888) 839-2700 between 7:00 am and 5:00 pm (PT). If you have any questions relating to shipping or billing, please contact our Customer Service Department at (888) 839-5600.

Thank you.

1. For ease of installation of your Banks High-Ram Intake, please familiarize yourself with the procedures by reading the entire manual before starting work. This instruction manual contains 8 pages of text, and 6 illustrations.
2. Disconnect the ground cable from the battery before beginning work. If there are two batteries, disconnect both.
3. Route and tie wires a minimum of 6 inches away from exhaust heat, moving parts and sharp edges. Clearance of 8 inches or more is recommended where possible.
4. The installation should be performed at time when the vehicle has been allowed to completely cool. This installation requires the installer to work near surfaces that may remain hot after the vehicle has been run.

Failure to allow the vehicle to cool may result in personal injury.

5. During installation, keep your work area and components clean to avoid possible dirt entry into the engine.
6. Banks recommends that a Pyrometer (EGT) gauge (Banks part# 63401) and a Boost gauge (Banks part# 63405) be installed to monitor performance and exhaust gas temperature of the vehicle. Banks also recommends the following:

Airflow Improvements:

1. Banks Monster® Exhaust

Std. Cab Long Bed w/ Cat	48640
Std. Cab Long Bed w/o Cat	48641
Quad Cab Long Bed w/ Cat	48642
Quad Cab Long Bed w/o Cat	48643
2. Banks Big Head Actuator	24331
3. Banks Ram-Air®		
Filter	41028
Service Kit	90094
4. Gauge Assembly		
Boost and Pyro	64507

Tools Required:

- Inch and metric combination or open-end wrenches
- Standard and flat head screwdrivers
- Torque wrench (lb-in)
- Gasket scraper

STOCK RAM REMOVAL

1. Loosen the clamp that holds the rubber hose at the inlet of the stock intake and slide the hose free of the intake inlet. Save the clamp for re-use.

Caution: Cover the intercooler up-pipe opening with a clean rag to prevent foreign objects from entering the intake tract.

2. Remove the bolt that holds the dipstick on the intake. Save the bolt for reuse. Gently push and move the dipstick and its holder to the rear of the engine compartment to gain access to the engine.

3. Remove the electric heater wire harness from the stock intake by pulling the plastic pin out. Remove the wire harness brackets that are mounted on the intake by removing the nut and the washer. Save the nut and the washer for re-use.

4. Unbolt and remove the 4 bolts at the base of the stock intake and remove the intake from the engine, being careful to not knock any debris into the intake through the electric heater element block.

5. Remove the stud bolt from the stock intake (see **Figure 1**), and install it onto Banks High-Ram at the same location.

6. Remove the three wires connecting the electric heater element block to the engine and remove the heater element block. Save the fasteners for re-use.

Caution: Cover the opening in the intake manifold with a clean rag to prevent foreign objects from entering the engine.

Figure 1

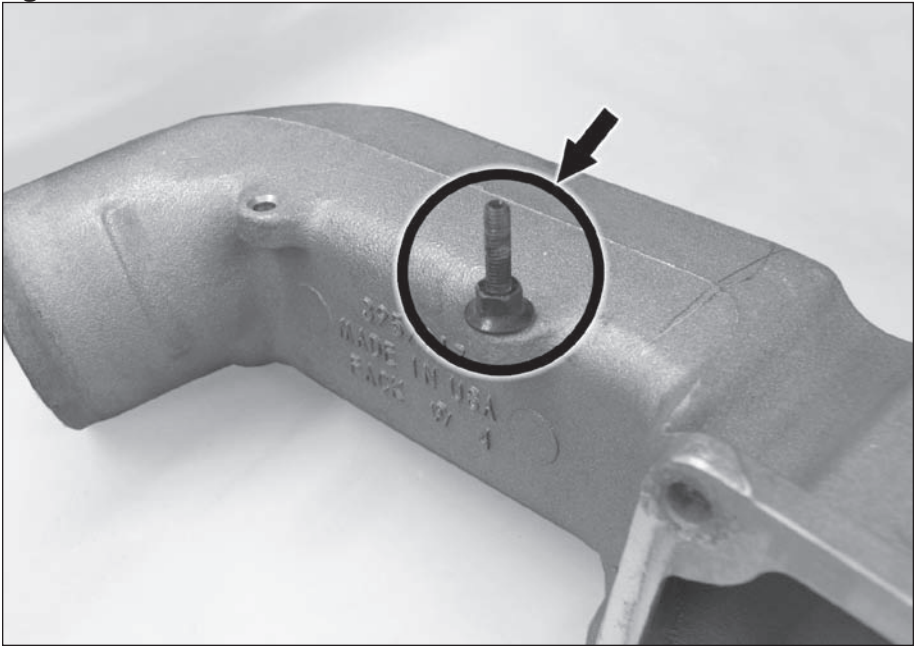

7. Being careful not to scratch or gouge the mating surfaces of the parts, completely remove the stock gaskets from both sides of the heater element block and intake manifold, using a gasket scraper as needed. Clean and dry all sealing surfaces thoroughly.

8. Reinstall the electric heater element block onto the intake manifold, placing one of the supplied gaskets between it and the intake manifold. Reattach the three electrical connections to the heater element.

BANKS HIGH-RAM™ INSTALLATION

Caution: The Banks studs have different threads on each end.

9. Make sure that the M8 ends go into the engine intake manifold. The two shorter studs go on the inboard side (closest to the valve cover). Apply the supplied thread lock compound at the M8 ends and hand-tighten the studs into the intake manifold.

10. Using the two 5/16"-24 nuts supplied, tighten the studs into the intake by threading both nuts onto the stud, then tighten the nuts against each other with two 1/2" open end wrenches. Tighten and torque the stud to 3-5 ft-lbs by turning the top nut. Remove the nuts from the stud by using two open end wrenches to loosen the nuts in relation to each other. Repeat the process for each stud. The process is shown in **Figure 2**.

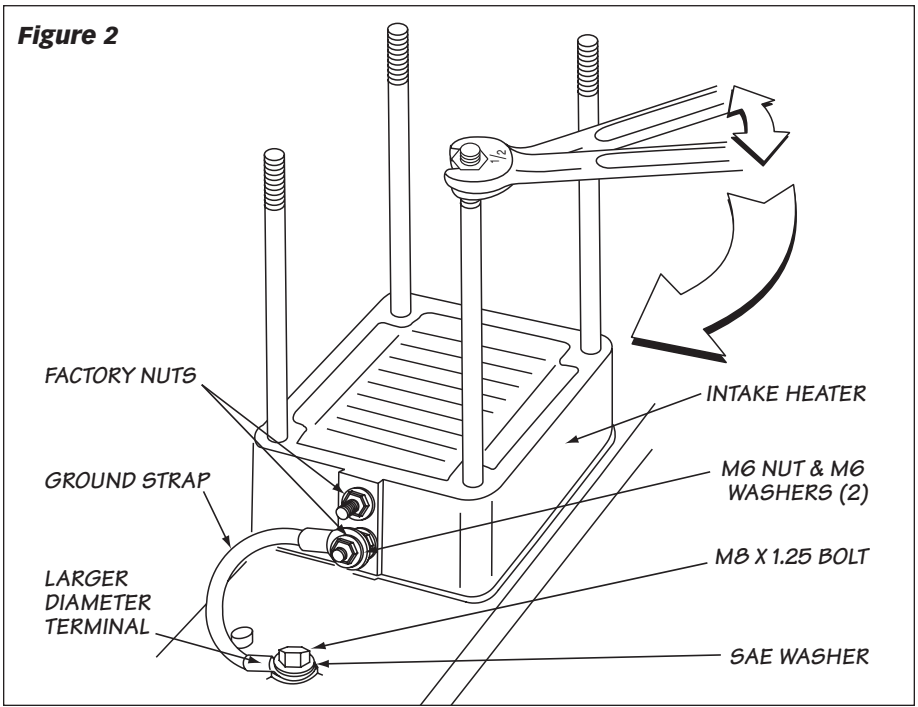

Figure 3

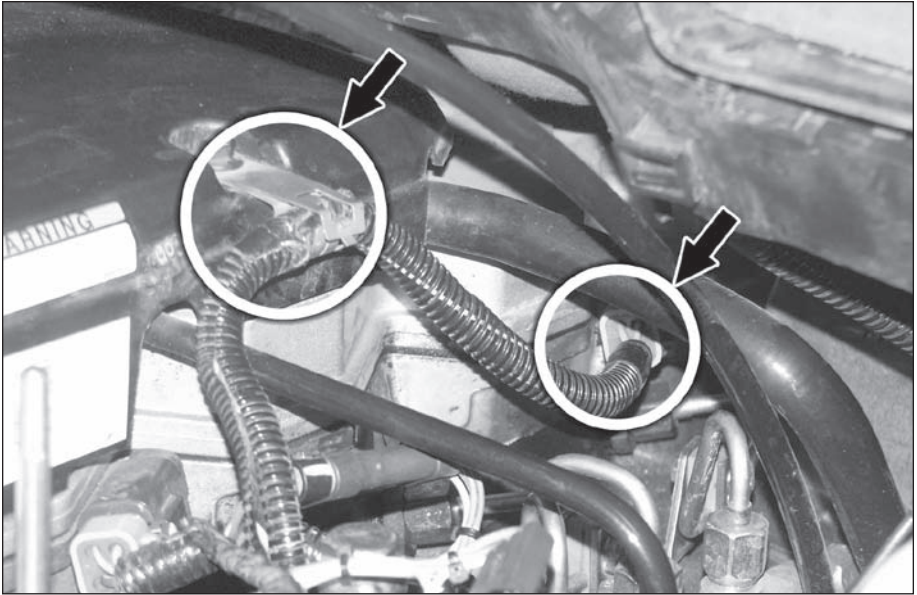
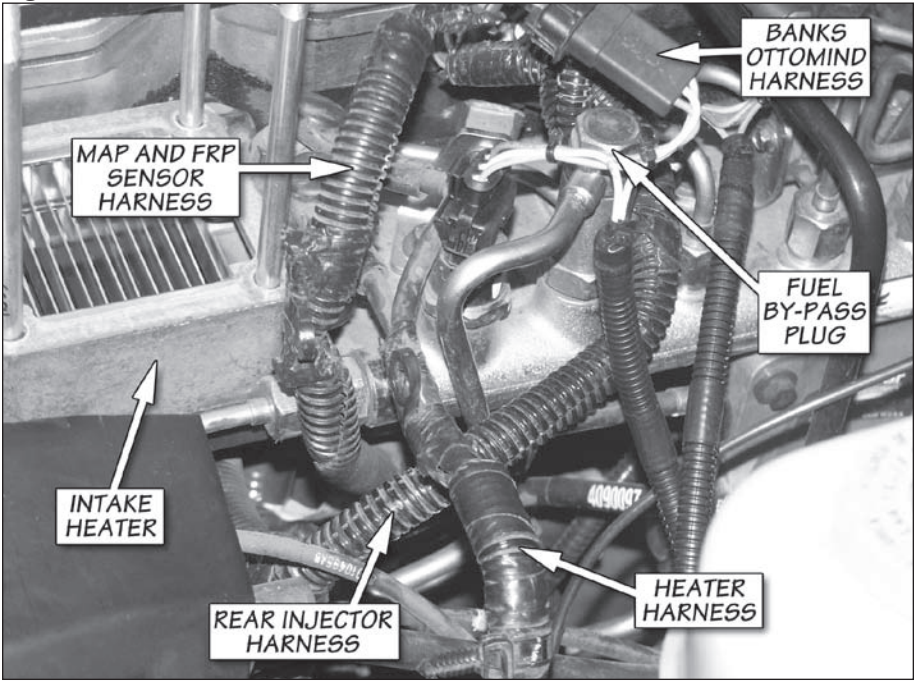

Figure 4



11. If your vehicle is NOT equipped with a factory ground strap on the intake heater, install the supplied ground strap from the intake heater to the engine. Put a 6-mm washer onto the bottom intake heater stud, leaving the factory heater nut installed. Next, install the smaller diameter ground strap terminal over the stud and retain with a 6-mm washer and nut. Route the other end of the ground strap to the threaded section on the engine and retain with a SAE washer and M8-1.25x 16 bolt. See **Figure 2**.

12. Using a flat screwdriver, loosen the clamp that holds the rear injector wire harness on the engine valve cover. Disconnect the injector wire harness from its connection. See

Figure 3. Remove the bracket used to hold this wire harness to the stock ram. Route this harness underneath the heater harness and around the fuel by-pass valve as shown in **Figure 4**. Place the wire harness back in the clamp that is on the valve cover and re-connect the wire harness. Make sure there is no sharp bending in the wire harness, and secure it by re-fastening the clamp. Secure the wire harness with the supplied cable ties.

13. Disconnect the MAP and the FRP sensors and relocate the wire harness in front of the heater harness as shown in **Figure 4**. Reconnect the sensors.

Figure 5

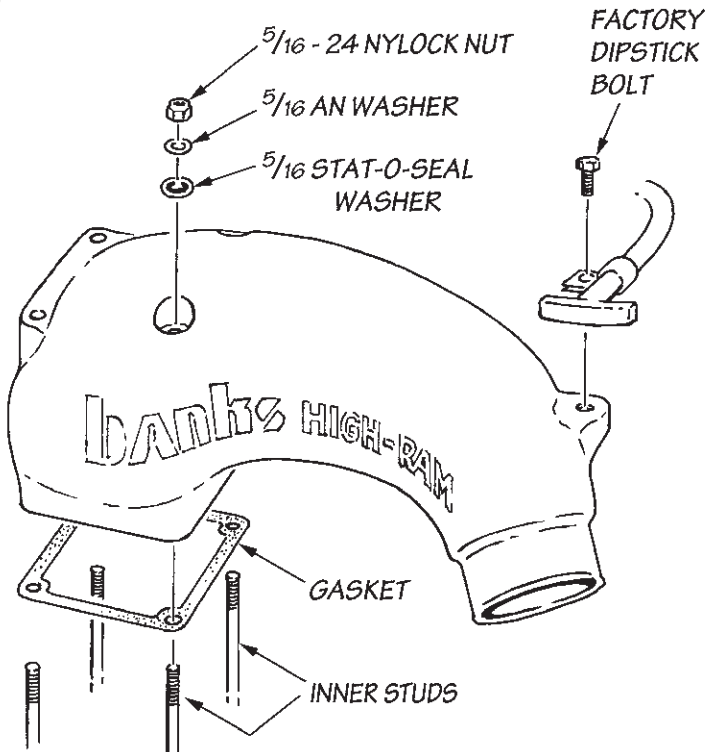

14. Slide the second provided intake gasket over the four studs and set the High-Ram in place on the studs. Twist a Stat-o-seal washer over the inner two studs, then over each stud install a flat $\frac{5}{16}$ " AN washer. Install a $\frac{5}{16}$ -24 nylock nut on each stud and tighten all four evenly between 140 to 150 lb-in. See **Figure 5**.

Caution: Use only handtools when tightening the High-Ram. Tighten snugly but do not overtighten. Damage to the High-Ram casting can result from the use of pneumatic tools or excessive tightening.

15. Place the supplied spacer on the stud on the High-Ram. Mount the bracket on the MAP and FRP wire

harness to the stud, and secure the bracket with the original washer and nut that were removed in **Step 3**.

16. Push the plastic pin on the heater wire harness into the hole close to the inlet on the High-Ram.

*NOTE: Before slipping any boost tubes and the corresponding hoses, into position, ensure that all connection ends are clean and free of any oil residue and contaminants. Clean compressor outlet and all connection points with a **non-oil based solvent** such as Acetone, Mineral Spirits, Denatured Alcohol or Lacquer Thinner. Read and follow the manufactures operation instruction for non-oil based solvent cleaner.*

Figure 6

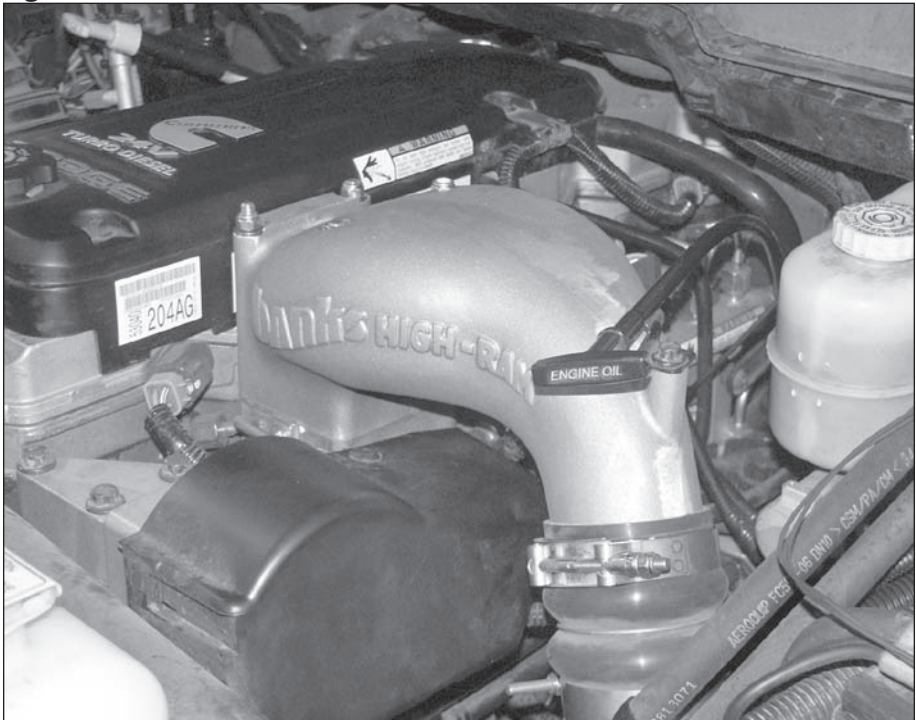

17. Remove all rags from the intercooler up-pipe opening and reconnect the rubber hose from the intercooler up-pipe to the High-Ram and tighten the clamp to 100 lb-in (11 N-m).

18. Rotate dipstick bracket and align the dipstick bracket hole to the hole on the High-Ram. Mount it to the High-Ram casting using the original factory bolt. See **Figures 5 and 6.**

*Note: For 2004-2007 model vehicles, locate the supplied corrugated loom in your kit and install over the main connector wires to protect it from rubbing against the dipstick. See **Figure 7.***

19. Reconnect the batteries. The Banks High Ram installation is now complete.

Figure 7

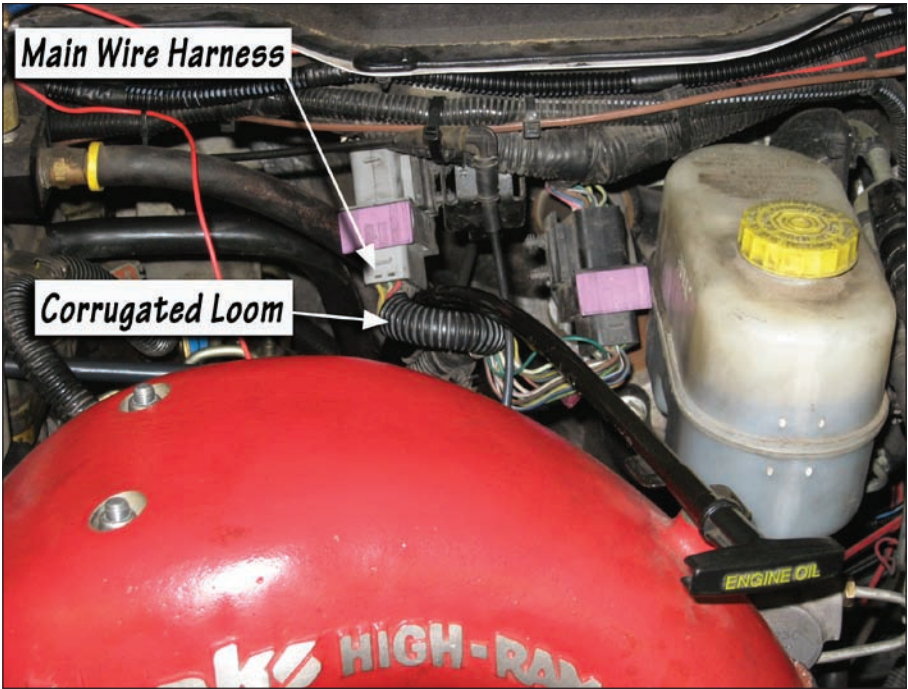

Gale Banks Engineering
546 Duggan Avenue • Azusa, CA 91702
(626) 969-9600 • Fax (626) 334-1743

Product Information & Sales: (888) 635-4565

bankspower.com