

Part Number: PT212-35070

Kit Contents

Item #	Quantity Reqd.	Description
1	1	Brush Guard Assembly
2	1	RH Upper Radiator Support
3	1	LH Upper Radiator Support
4	1	RH Bumper Support Plate
5	1	LH Bumper Support Plate

Hardware Bag Contents

Item #	Quantity Reqd.	Description
1	1	Instruction Sheet
2	4	M8 x 20 x 1.25 Hex Button head Bolt
3	4	Spacer (8mm Washer)
4	9	M6 x 16 x 1.0 Hex Flange Bolt
5	2	M6 Hex Flange Nut
6	2	M6 Washer
7	1	Drill Paper Template

Additional Items Required For Installation

Item #	Quantity Reqd.	Description

Conflicts

Hood Protector

Recommended Tools

Personal & Vehicle Protection	Notes
Safety Glasses	
Special Tools	Notes
Installation Tools	Notes
Ratchet	3/8" & 1/4"
Sockets 1/4" & 3/8"	13 mm, 10mm, 5mm hex 6"long
Extensions	3/8"-3", 3/8" -18" 1/4" - 12", 1/4" -18"
Wrench	10mm
Torque Wrenches	1/4", 3/8" drive
Utility Knife	
Clip Removal Tool	
Masking Tape	
Drill & hole saw	Hole saw 22 mm or 7/8" Hole saw 25 mm or 1"
Cardboard	4"x4"
Drill Motor	
Shop Vacuum	
Special Chemicals	Notes

NOTE: Part number of this accessory may not be the same as the part number shown.

--	--

General Applicability

--

Recommended Sequence of Application





Item #	Accessory
1	Auxiliary lamps on Brush Guard (if applicable)
2	Brush Guard
3	Skid Plate

*Mandatory

Vehicle Service Parts (may be required for reassembly)

Item #	Quantity Reqd.	Description
1		
2		
3		

Legend

	STOP: Damage to the vehicle may occur. Do not proceed until process has been complied with.
	OPERATOR SAFETY: Use caution to avoid risk of injury.
	CAUTION: A process that must be carefully observed in order to reduce the risk of damage to the accessory/vehicle and to ensure a quality installation.
	TOOLS & EQUIPMENT: Used in Figures calls out the specific tools and equipment recommended for this process.
	REVISION MARK: This mark highlights a change in installation with respect to previous issue.

Care must be taken when installing this accessory to ensure damage does not occur to the vehicle. The installation of this accessory should follow approved guidelines to ensure a quality installation.

These guidelines can be found in the "Accessory Installation Practices" document.

This document covers such items as:-

- Vehicle Protection (use of covers and blankets, cleaning chemicals, etc.).
- Safety (eye protection, rechecking torque procedure, etc.).
- Vehicle Disassembly/Reassembly (panel removal, part storage, etc.).
- Electrical Component Disassembly/Reassembly (battery disconnection, connector removal, etc.).

Please see your Toyota dealer for a copy of this document.

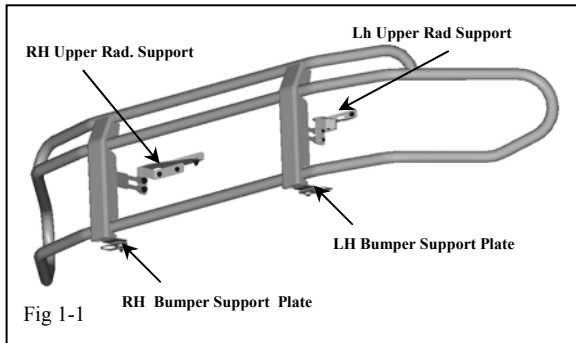

Fig 1-1

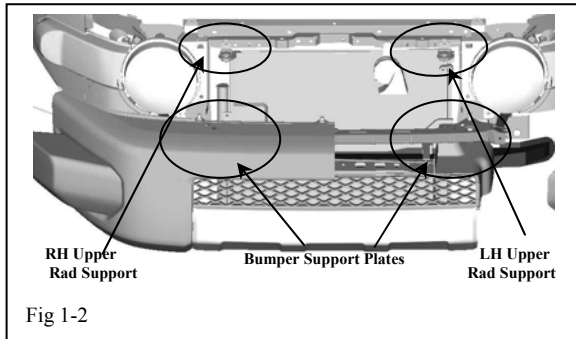

Fig 1-2

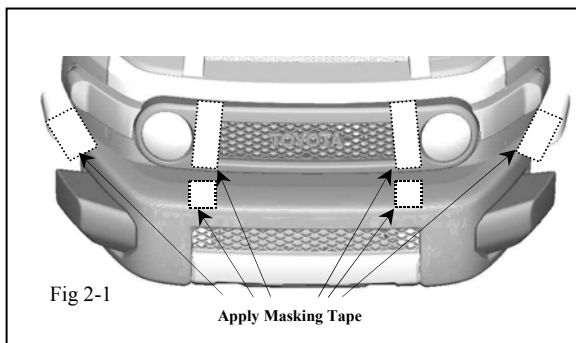

Fig 2-1

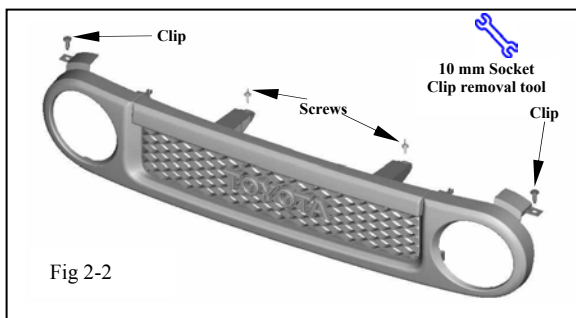

Fig 2-2

1. Remove Brush Guard from Packaging.

- (a) Remove Brush Guard from package and place on a clean protected surface.
- (b) Verify kit contents and inspect brush guard for damage. (Fig. 1-1)

- (c) Refer to Fig. 1-2 throughout the instructions for vehicle mounting locations.

2. Vehicle Preparation for Brush Guard Installation.

- (a) To prevent scratching to the bumper fascia, grille, and fenders during brush guard installation, apply masking tape to the areas shown in Fig. 2-1.
- (b) Remove grille from vehicle by removing 2 screws and 2 clips (Fig. 2-2). Save for reinstallation.

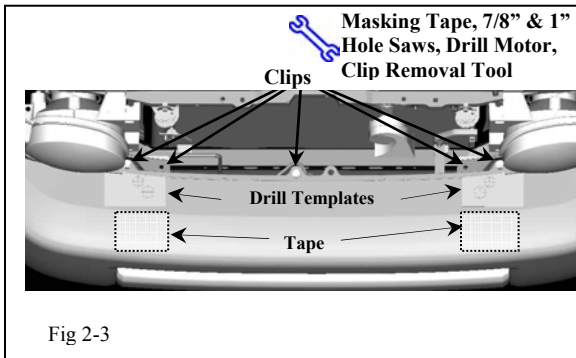

- (c) Remove the five plastic clips from fascia attached to the steel bumper support (Fig. 2-3).

3. Brush Guard Preparation for Installation.



- (a) Apply masking tape to headlight to prevent damage. Line up the drill template to the bumper fascia using the ridge of the fascia as a guide (Fig. 3-1). Secure the templates with tape.

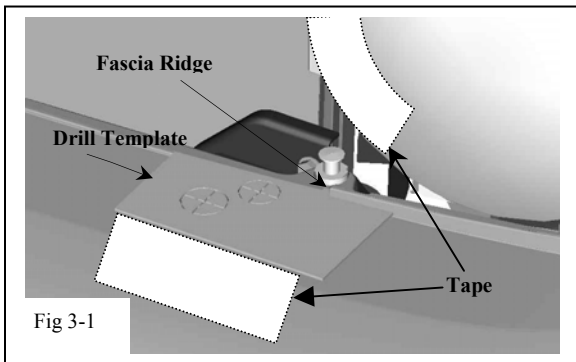

- (b) Mark hole location on fascia.



- (c) Insert cardboard 4" x 4" between fascia and the metal bumper support to prevent scratching or drilling bumper support. Drill holes through the fascia using the template provided (Fig. 3-2).

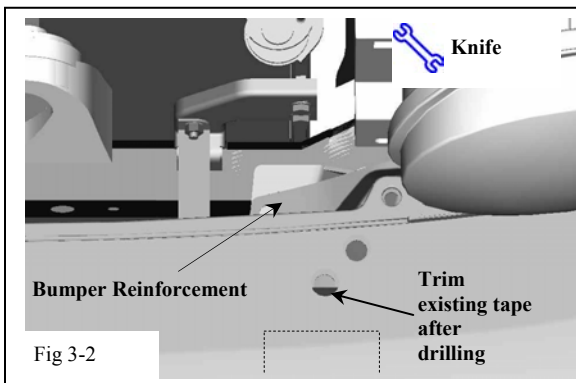

- (d) Trim existing black tape around vehicle holes (Fig. 3-2).



- (e) Clean and remove the burrs from drilled holes.

- (f) Vacuum the plastic shavings.

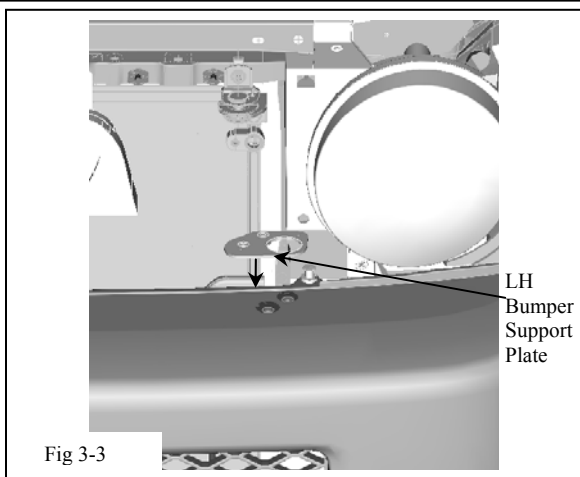

Fig 3-3

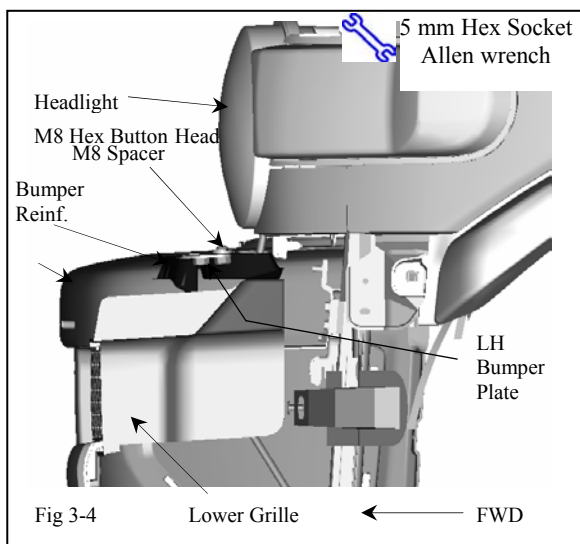

Fig 3-4

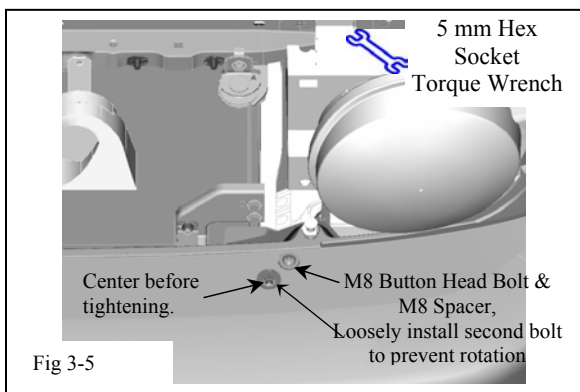

Fig 3-5

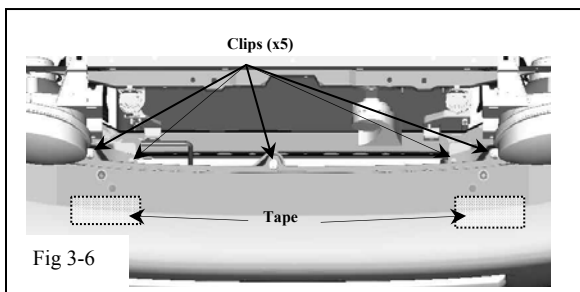



Fig 3-6

 (g) Install the bumper support plate by sliding it carefully under the fascia and bumper reinforcement panel on the vehicle (Fig 3-3 & Fig 3-4). Line up the two holes drilled in fascia with bracket holes.

(h) Install one M8 hex button head bolt and spacer (M8 washer) in rear most 7/8" hole. This attaches the bumper support plate to the bumper reinforcement panel on the vehicle. Loosely install the second button head bolt temporarily to prevent rotation of the bracket. (Fig 3-5).

(i) Repeat (g-h) for the RH bumper support plate.

NOTE: Check the M8 hex button head bolt to make sure it is in the center of the existing hole in the vehicle, adjust if necessary. Torque to 12.9 N-m (114 in-lbs) (Fig 3-5).

(j) Reinstall the five plastic clips in fascia (Fig. 3-6).

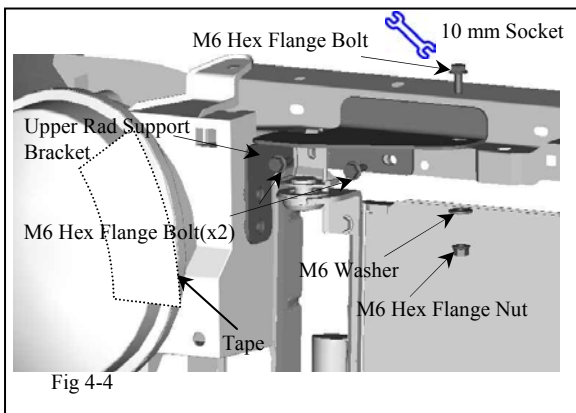
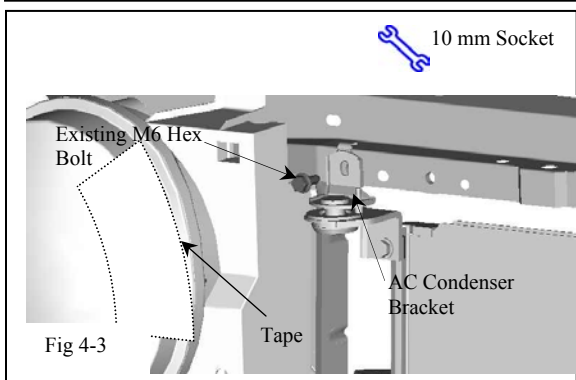
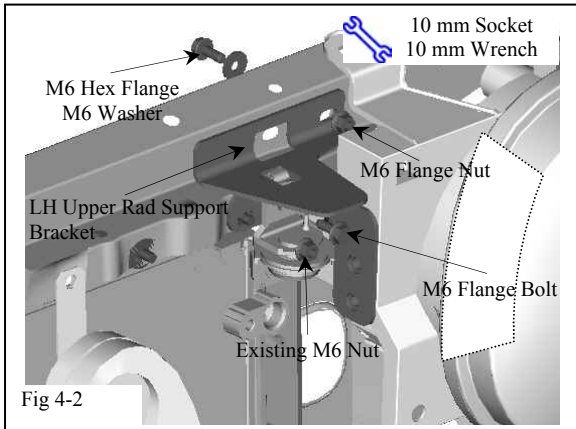
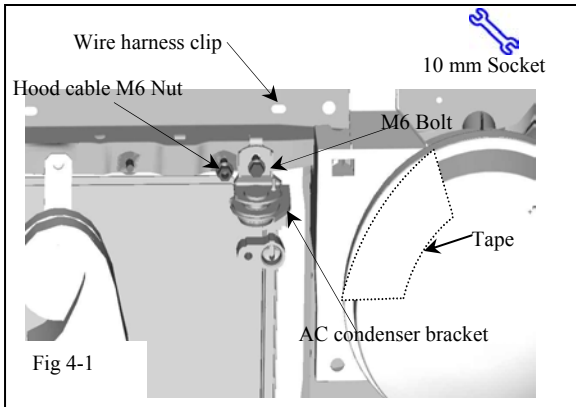

4. Upper radiator bracket installation.



(a) Locate, remove, and discard existing M6 bolt from the upper AC condenser brackets (Fig 4-1 Driver's side). Remove the M6 nut for the hood cable on the drivers side, save to reuse. Unclip wire harness on drivers side.

(b) Install LH upper radiator support by sliding it under the AC condenser bracket. Fasten using two M6 hex flange bolts, one M6 hex flange nut and one M6 washer. Reinstall M6 flange nut to reattach the hood cable and bracket. (Fig 4-2).-

(c) On the passenger side of the vehicle, slide the RH Upper Radiator Support under the AC condenser bracket loosely, and install the three M6 flange bolts, one M6 flange nut, and washer (Fig 4-3 & 4-4).



(d) Torque M6 hardware to 10.8 N-m or (96 in-lbs).

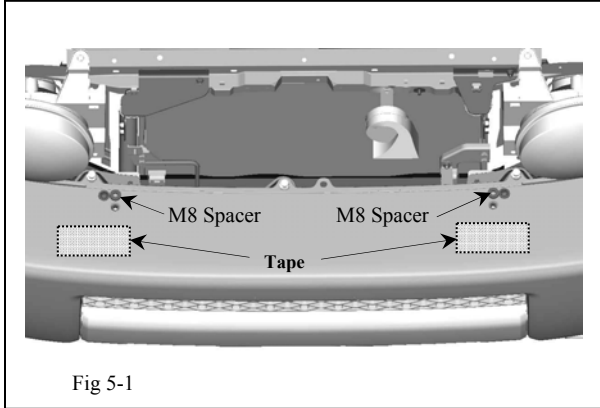

5. Brush Guard Installation.

Note: If installing auxiliary lamps to Brush Guard they must be fastened to the Brush Guard before vehicle attachment.

- (a) Set spacer (8 mm washer) in the two remaining 1” holes drilled in the bumper fascia.(one per side) (Fig 5-1).

- (b) Remove tape from headlamps



- (c) Reinstall the grille.

- (d) Carefully align the Brush Guard through the grille and set on top of the spacers. (Fig 5-2)

- (e) Loosely attach the Brush Guard with two M8 hex button head bolt to the bumper support brackets installed in Step 3 (one per side). (Fig 5-3) . Apply tape to brush guard and grille in the area of potential tool contact when tightening the M8 hardware.

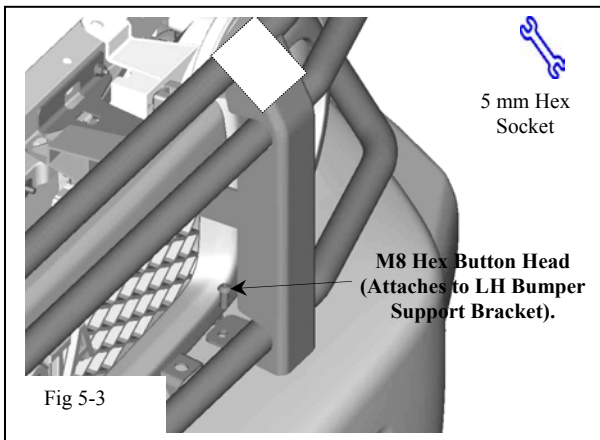
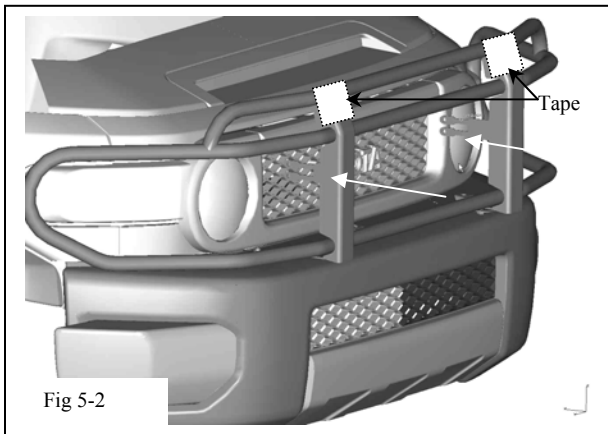

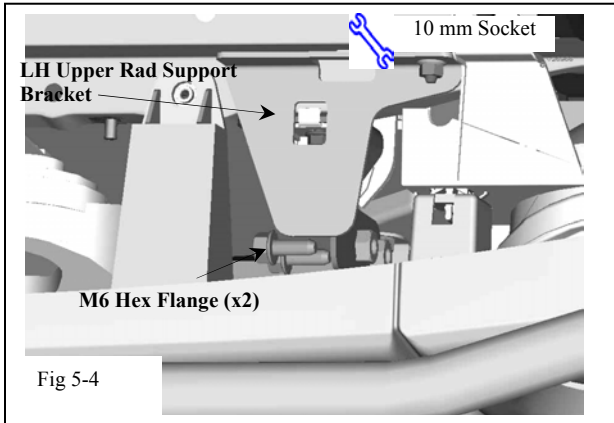

(f) Attach M6 flange bolts to the Upper Radiator Support brackets (Installed in Step 4). Check to make sure Brush Guard is visually centered on vehicle (Fig 5-4) (Fig 5-5) & (Fig 5-6).

(g) Torque two M8 hex button head bolt to 12.9 N-m (114 in-lbs) (Fig 5-3).

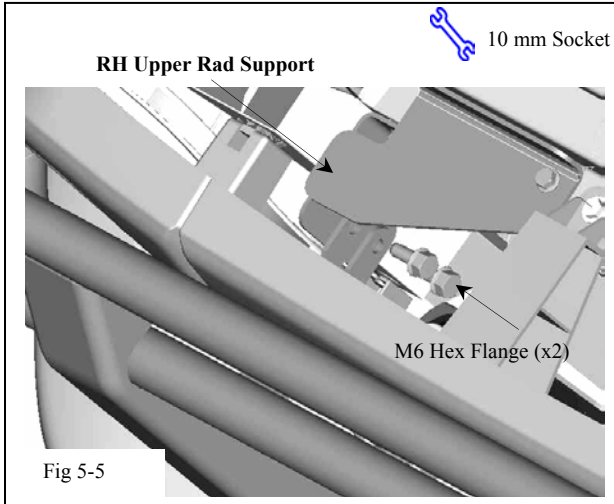

(h) Pull brushguard out from vehicle to create maximum clearance. Torque remaining M6 hardware to 14.6 N-m or (129 in-lbs).

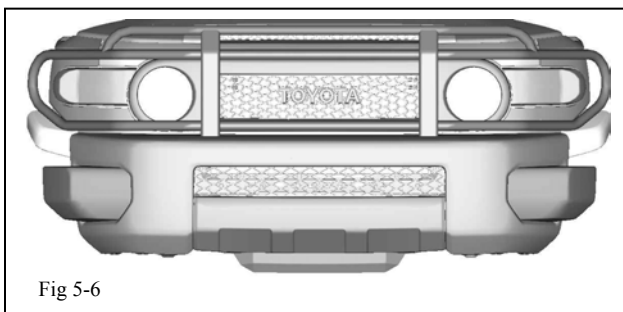

TOYOTA FJ CRUISER 2007 - BRUSH GUARD
Checklist - these points **MUST** be checked to ensure a quality installation.

Check:

Look For:

Accessory Function Checks

- Visual check of Brush Guard
- Check Gap

Visually centered left to right on vehicle.
Hood, fenders, bumper, grill

Vehicle Function Checks