

IGNITION COIL COMPONENTS

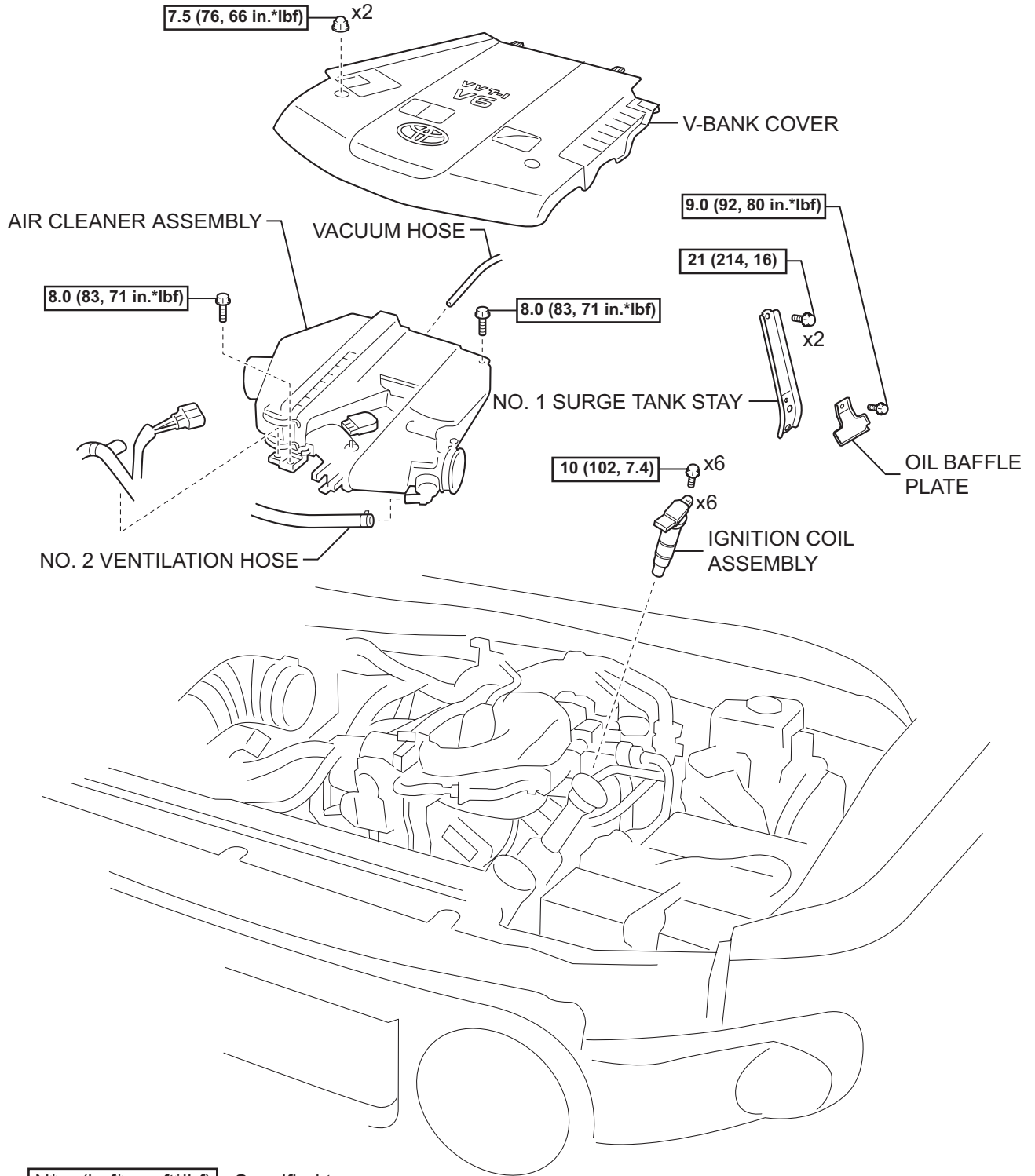

N*m (kgf*cm, ft*lbf) : Specified torque



REMOVAL

1. DISCONNECT CABLE FROM NEGATIVE BATTERY TERMINAL
2. REMOVE V-BANK COVER (See page [ES-428](#))
3. REMOVE AIR CLEANER ASSEMBLY (See page [ES-429](#))
4. REMOVE OIL BAFFLE PLATE (See page [FU-11](#))
5. REMOVE NO. 1 SURGE TANK STAY (See page [FU-11](#))
6. DISCONNECT VENTILATION HOSE
 - (a) Disconnect the ventilation hose from the intake air surge tank.

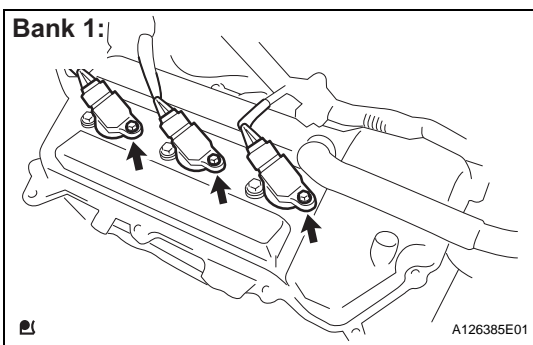
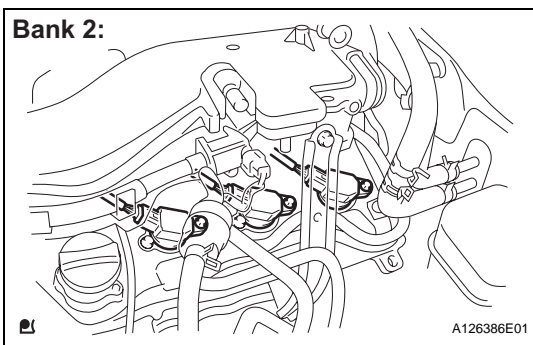
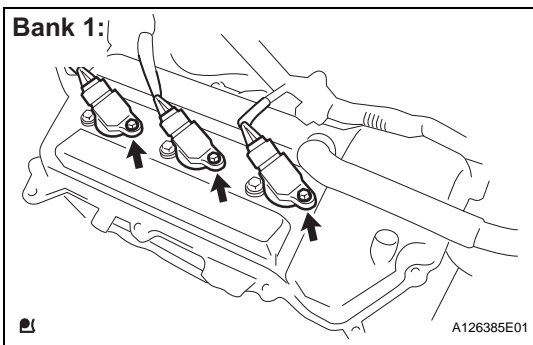
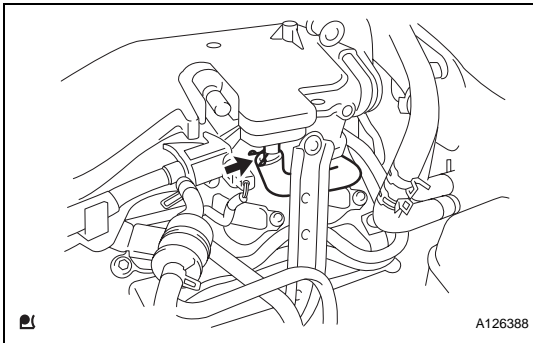

7. REMOVE IGNITION COIL ASSEMBLY

- (a) For Bank 1:
 - (1) Disconnect the 3 connectors.
 - (2) Remove the 3 bolts, then remove the 3 ignition coils.
- (b) For Bank 2:
 - (1) Disconnect the 3 connectors.
 - (2) Remove the 3 bolts, then remove the 3 ignition coils.

INSTALLATION

1. INSTALL IGNITION COIL ASSEMBLY

- (a) For Bank 1:
 - (1) Install the 3 ignition coils with the 3 bolts.
Torque: 10 N*m (102 kgf*cm, 7.4 ft.*lbf)
 - (2) Connect the 3 ignition coil connectors.

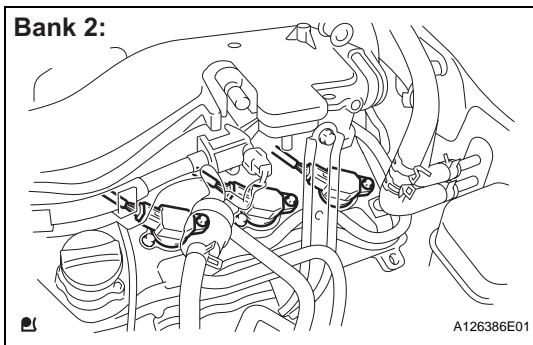

- (b) For Bank 2:
- (1) Install the 3 ignition coils with the 3 bolts.
Torque: 10 N*m (102 kgf*cm, 7.4 ft.*lbf)
 - (2) Connect the 3 ignition coil connectors.

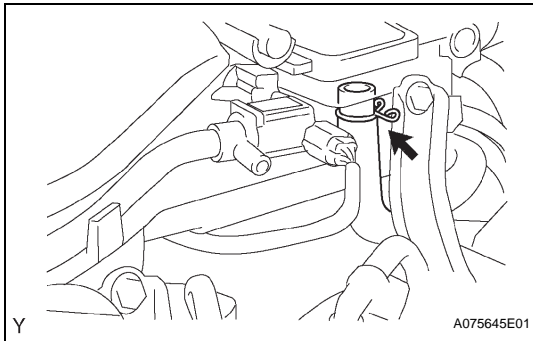

2. **CONNECT VENTILATION HOSE**
 - (a) Connect the ventilation hose to the intake air surge tank.
3. **INSTALL NO. 1 SURGE TANK STAY (See page [FU-19](#))**
4. **INSTALL OIL BAFFLE PLATE (See page [FU-19](#))**
5. **INSTALL AIR CLEANER ASSEMBLY (See page [ES-431](#))**
6. **CONNECT CABLE TO NEGATIVE BATTERY TERMINAL**
Torque: 3.9 N*m (40 kgf*cm, 35 in.*lbf)
7. **INSPECT IGNITION TIMING (See page [EM-1](#))**
8. **INSPECT ENGINE IDLING SPEED (See page [EM-2](#))**
9. **INSTALL V-BANK COVER (See page [ES-431](#))**