

AUTO LSD Indicator Light Remains ON

DESCRIPTION

This is the AUTO LSD main switch circuit. When the AUTO LSD switch is pushed on, the AUTO LSD function is available and the AUTO LSD indicator light illuminates.

HINT:

The AUTO LSD does not operate even if the AUTO LSD switch is pressed under the following conditions:

- TRAC or VSC system is faulty.
- Temperature inside the hydraulic brake booster increases and the AUTO LSD operation is suspended.

WIRING DIAGRAM

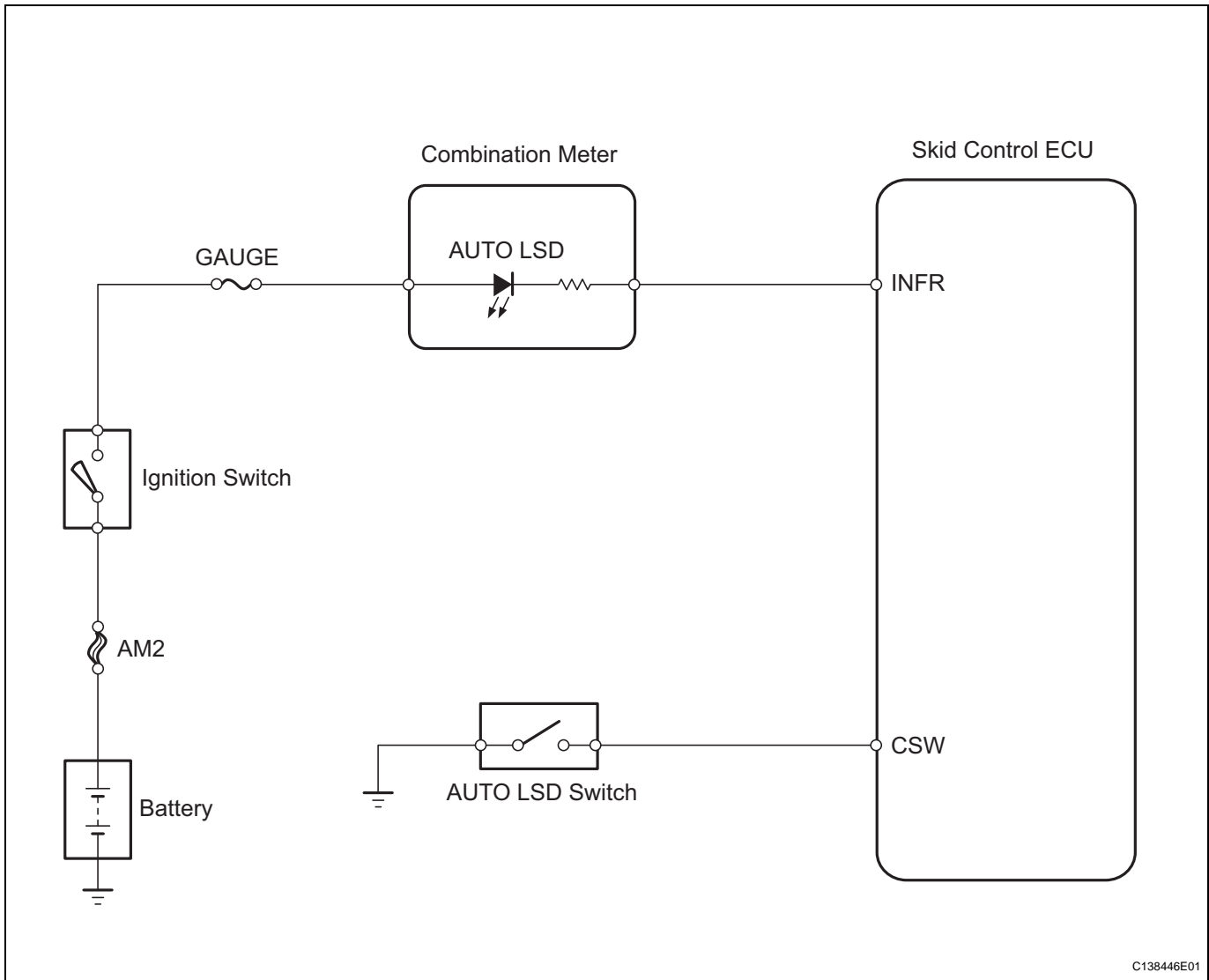

INSPECTION PROCEDURE

NOTICE:

When replacing the master cylinder solenoid, perform zero point calibration (See page [BC-24](#)).

1 INSPECT AUTO LSD SWITCH

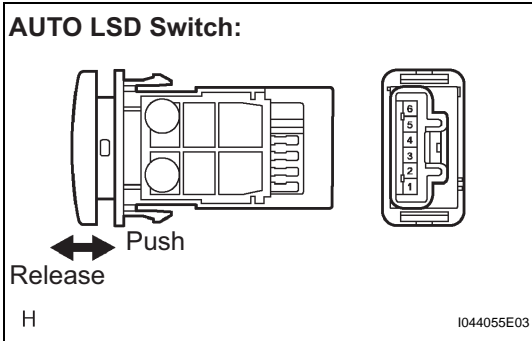

- (a) Remove the AUTO LSD switch.
 - (b) Disconnect the AUTO LSD switch connector.
 - (c) Measure the resistance.
- Standard resistance**

Tester Connection	Switch Condition	Specified Condition
3 - 4	Released	10 kΩ or higher
3 - 4	Pushed in	Below 1 Ω

NG → **REPLACE AUTO LSD SWITCH**

OK

2 CHECK HARNESS AND CONNECTOR (SKID CONTROL ECU - AUTO LSD SWITCH)

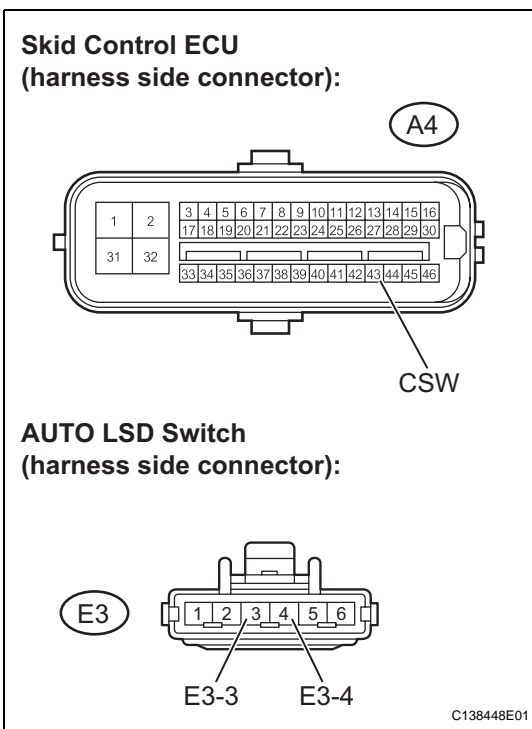

- (a) Disconnect the skid control ECU connector.
 - (b) Disconnect the AUTO LSD connector.
 - (c) Measure the resistance.
- Standard resistance**

Tester Connection	Specified Condition
A4-43 (CSW) - E3-3	Below 1 Ω
A4-43 (CSW) - Body ground	10 kΩ or higher
E3-4 - Body ground	Below 1 Ω

NG → **REPAIR OR REPLACE HARNESS OR CONNECTOR**

OK

BC

3 CHECK HARNESS AND CONNECTOR (SKID CONTROL ECU - COMBINATION METER)

**Skid Control ECU
(harness side connector):**

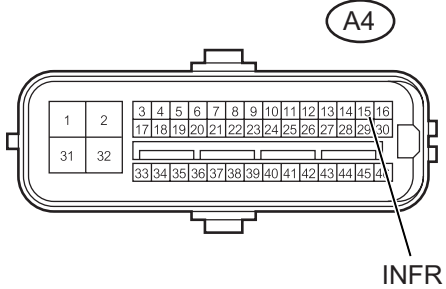

**Combination Meter
(harness side connector):**

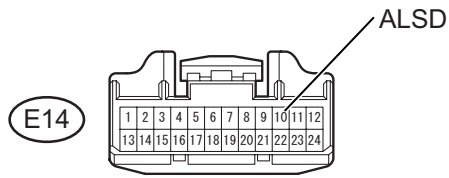

C135294E03

- (a) Disconnect the skid control ECU connector.
- (b) Disconnect the combination meter connector.
- (c) Measure the resistance.

Standard resistance

Tester Connection	Specified Condition
A4-15 (INFR) - E14-10 (ALSD)	Below 1 Ω
A4-15 (INFR) - Body ground	10 kΩ or higher

NG → **REPAIR OR REPLACE HARNESS OR CONNECTOR**

OK

4 INSPECT COMBINATION METER ASSEMBLY

- (a) Check the combination meter system (See page [ME-29](#)).

OK:

Combination meter is normal.

NG → **REPLACE COMBINATION METER ASSEMBLY**

OK

REPLACE MASTER CYLINDER SOLENOID