

REPLACEMENT

1. REMOVE FRONT SIDE MEMBER TO FRONT SUSPENSION CROSSMEMBER BRACE
2. REMOVE NO. 1 ENGINE UNDER COVER
3. REMOVE REAR ENGINE UNDER COVER ASSEMBLY
4. DRAIN DIFFERENTIAL OIL
5. REMOVE DIFFERENTIAL VACUUM ACTUATOR ASSEMBLY

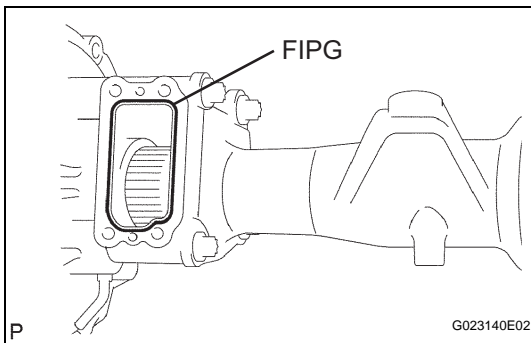
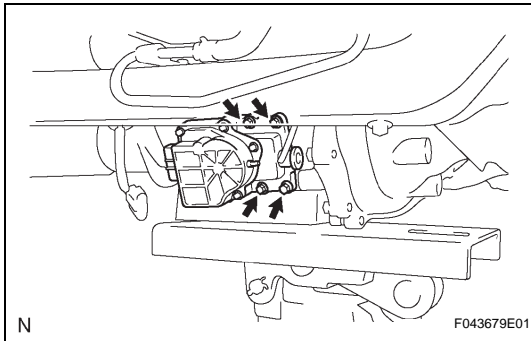
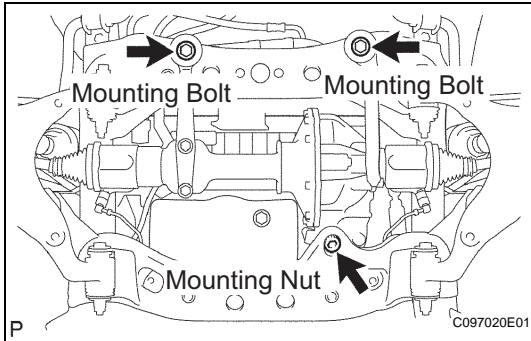

- (a) Remove the bolt and disconnect the differential breather tube bracket.
- (b) Support the differential with a jack.
- (c) Remove differential mounting nut No. 1.
- (d) Remove the 2 mounting bolts and 2 nuts.
- (e) Disconnect the actuator hose and connector.
- (f) Lower the jack.
- (g) Remove the 4 bolts and vacuum actuator.

6. INSTALL DIFFERENTIAL VACUUM ACTUATOR ASSEMBLY

- (a) Remove any old FIPG material.

NOTICE:
Be careful not to drop oil on the contact surfaces of the actuator and clutch case.
- (b) Using gasoline or alcohol, clean any residual FIPG material on the contact surfaces.
- (c) Apply FIPG to the differential tube, as shown in the illustration.

FIPG:

Part No. 08826-00090, THREE BOND 1281 or the equivalent

HINT:

Install the actuator within 10 minutes of applying FIPG.

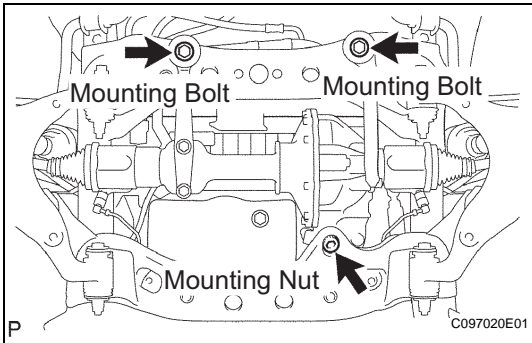
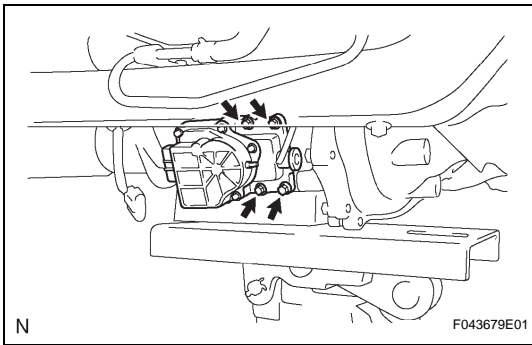

- (d) Clean the threads of the 4 bolts and retainer bolt holes with toluene or trichloroethylene.
- (e) Apply adhesive to 2 or 3 threads at the tip of the bolt.

Adhesive:

Part No. 0883-00070, THREE BOND 1281 or the equivalent

- (f) Install the differential vacuum actuator onto the differential tube with the 4 bolts.
Torque: 21 N*m (210 kgf*cm, 15 ft.*lbf)
- (g) Connect the actuator hose and connector.
- (h) Support the differential with a jack.
- (i) Install the 2 front mounting bolts and 2 nuts.
Torque: 137 N*m (1,400 kgf*cm, 101 ft.*lbf)
- (j) Install differential mounting nut No. 1.
Torque: 87 N*m (887 kgf*cm, 64 ft.*lbf)
- (k) Install the differential breather tube bracket with the bolt.
Torque: 13 N*m (133 kgf*cm, 10 ft.*lbf)

7. REFILL DIFFERENTIAL OIL

- (a) Refill differential oil (see page [DF-3](#)).

8. CHECK FOR DIFFERENTIAL OIL LEAKAGE

9. INSTALL REAR ENGINE UNDER COVER ASSEMBLY

10. INSTALL NO. 1 ENGINE UNDER COVER

11. INSTALL FRONT SIDE MEMBER TO FRONT SUSPENSION CROSSMEMBER BRACE